



美萨实业

上海美萨实业有限公司

Shanghai MSA Industries Co.,Ltd

模切工艺介绍

地址：上海市金山区金张公路625号 <http://www.shmsa.com>

电话：021-39901539 18017127130 13817755198

提供缓冲/密封/防震 解决方案，提供导热/隔热 解决方案
提供绝缘/防火/安全 解决方案，提供粘接/密合 解决方案



01

PART ONE
典型工艺
Typical Process

提供缓冲/密封/防震 解决方案, 提供导热/隔热 解决方案
提供绝缘/防火/安全 解决方案, 提供粘接/密合 解决方案



1.1 平刀异步工艺原理(Principle of Asynchronous Process for Flat Knife)

带刀无痕异步模切
Non marking asynchronous
die-cutting with knife

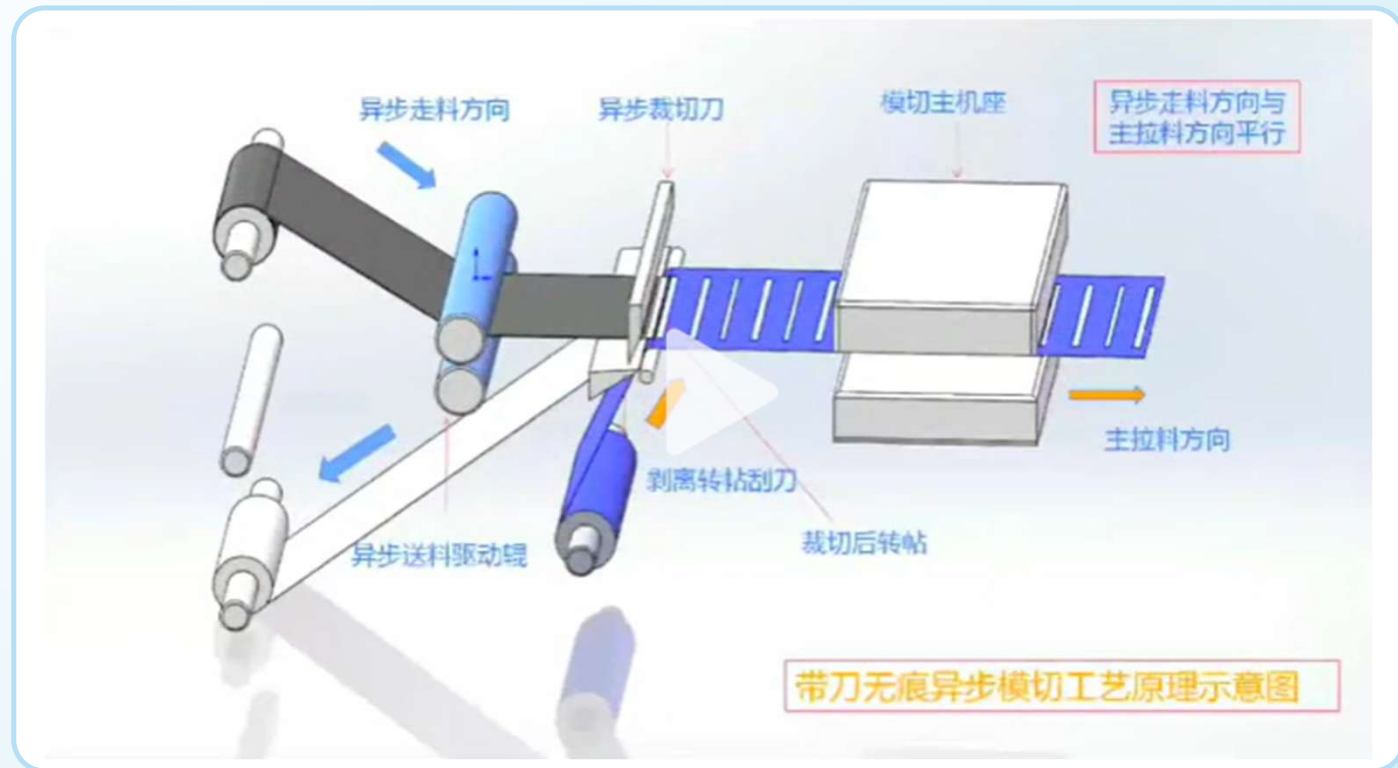

1.2 平刀异步工艺原理(Principle of Asynchronous Process for Flat Knife)

带刀有痕异步模切
Asynchronous die-cutting
with knife marks

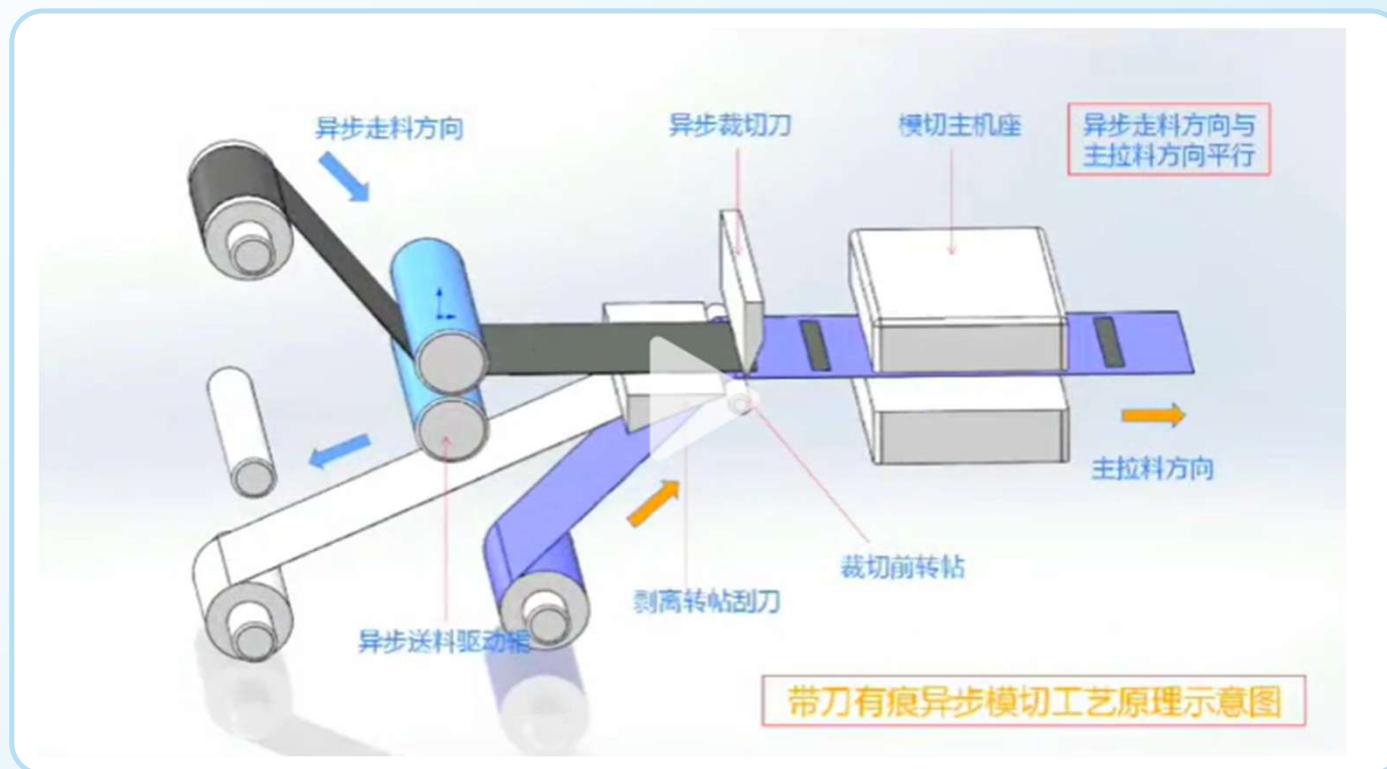

1.3 平刀异步工艺原理(Principle of Asynchronous Process for Flat Knife)

模内异步模切
In mold asynchronous die-cutting

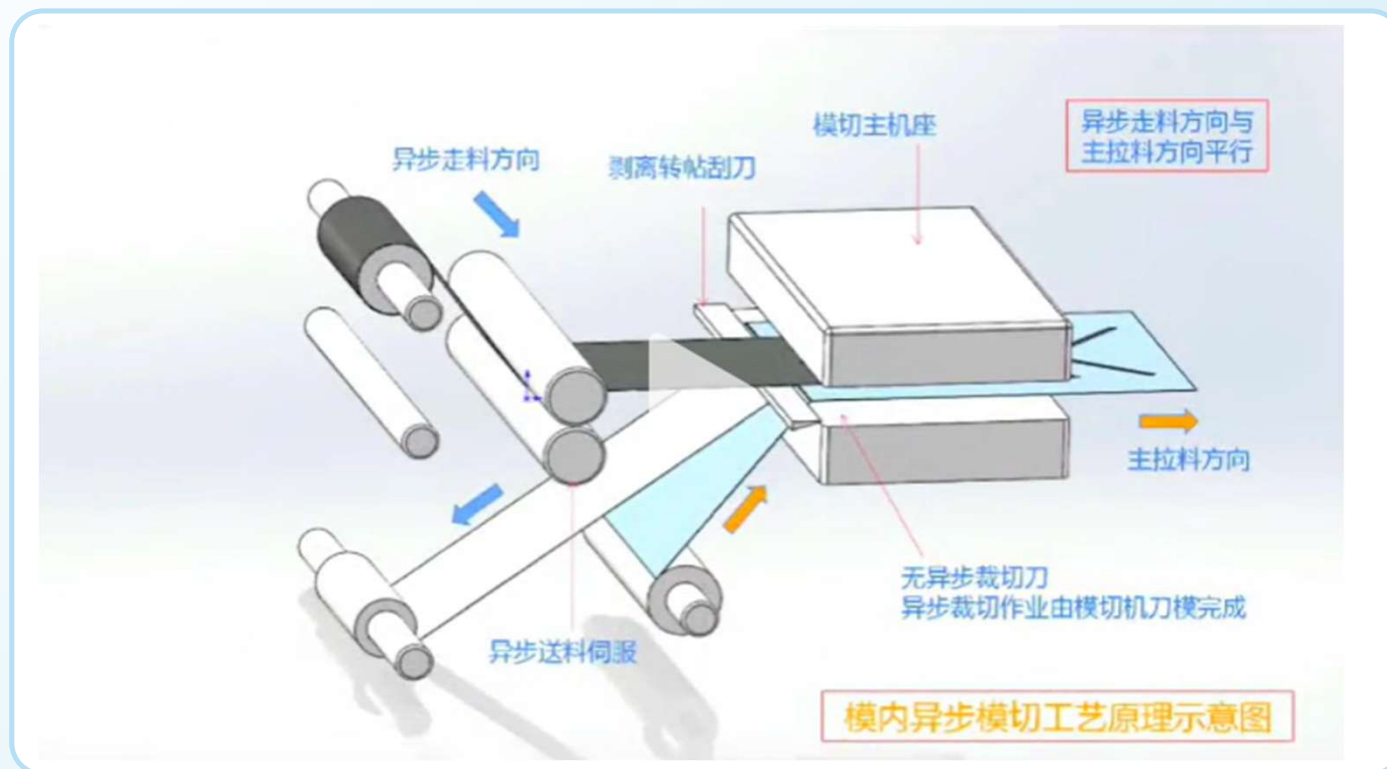

1.4 平刀异步工艺原理(Principle of Asynchronous Process for Flat Knife)

上异步模切工艺
Asynchronous die-cutting
process

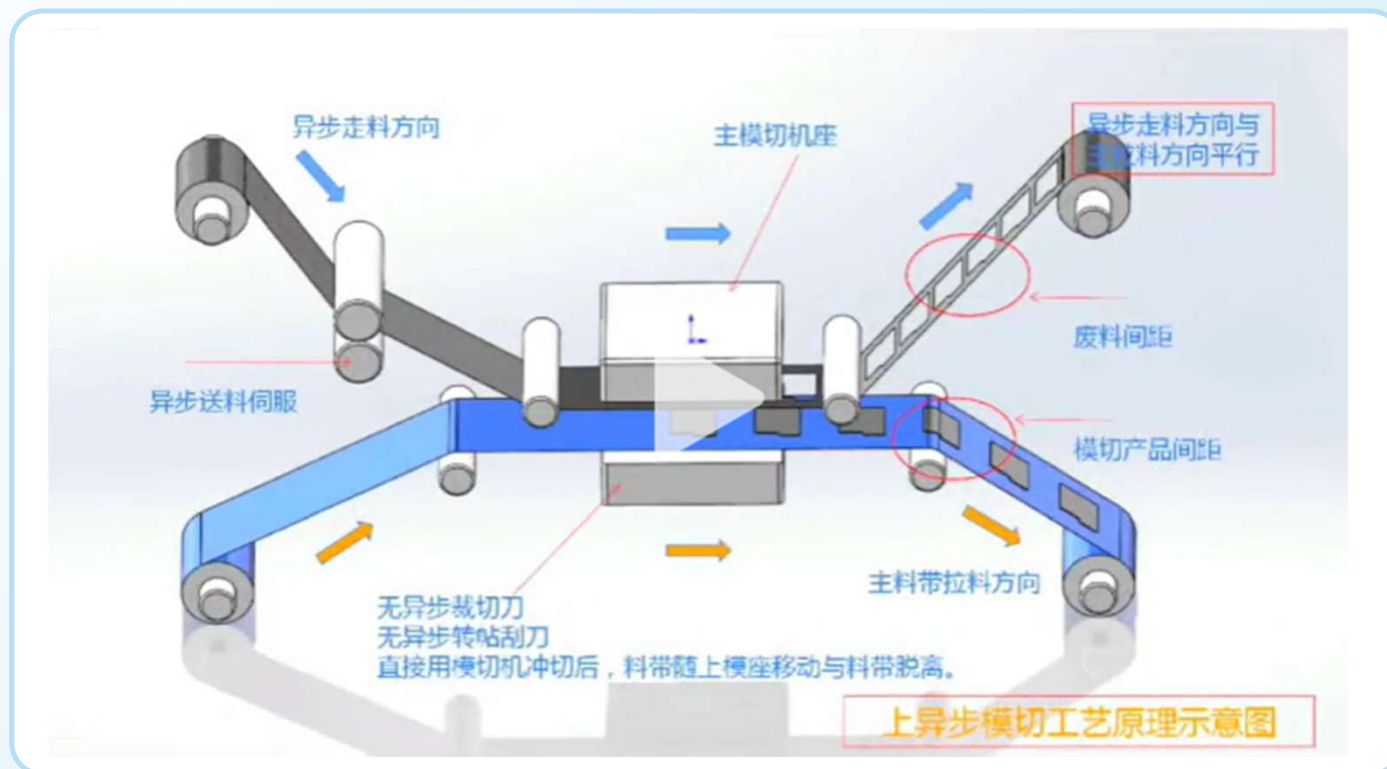

1.5 平刀异步工艺原理(Principle of Asynchronous Process for Flat Knife)

十字异步模切工艺
Cross asynchronous die-cutting process

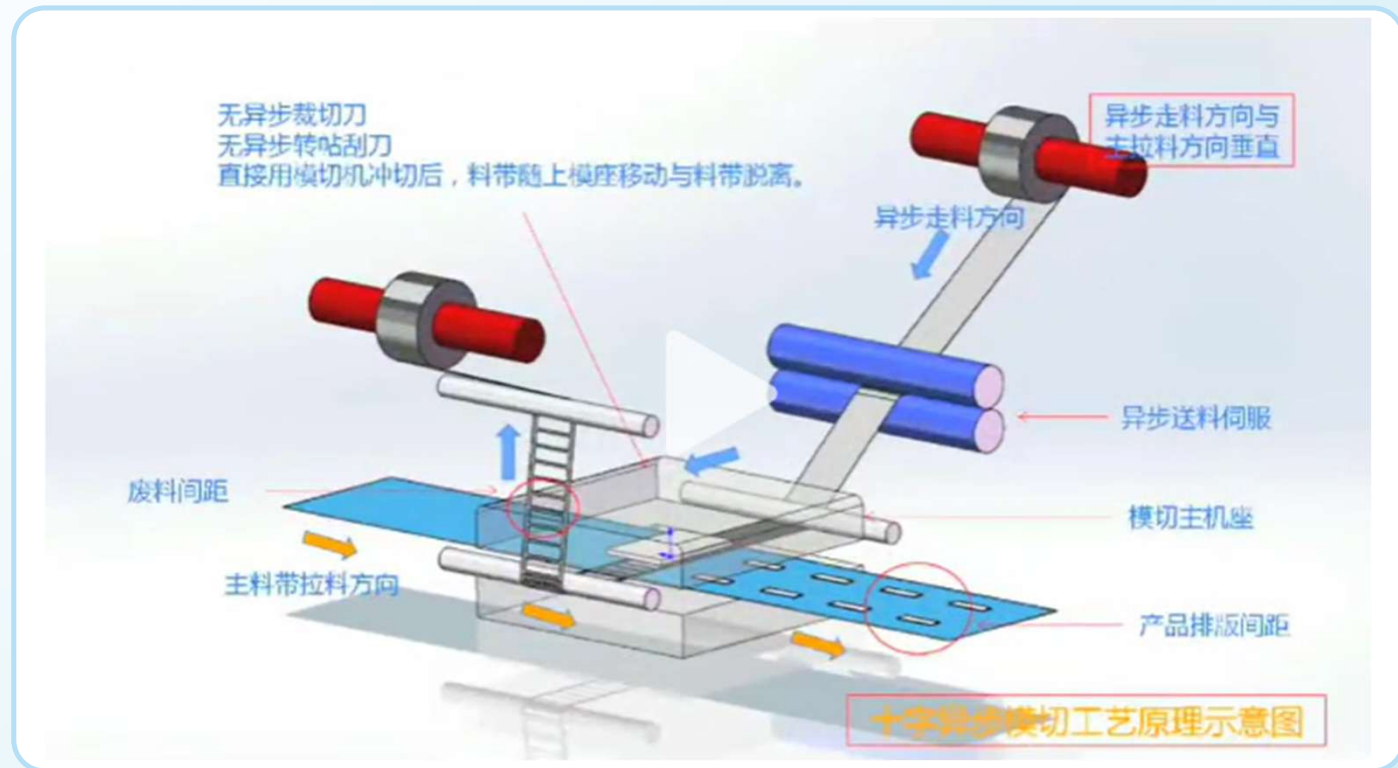

1.6 平刀异步工艺原理(Principle of Asynchronous Process for Flat Knife)

双异步模切工艺
Double asynchronous die-cutting process

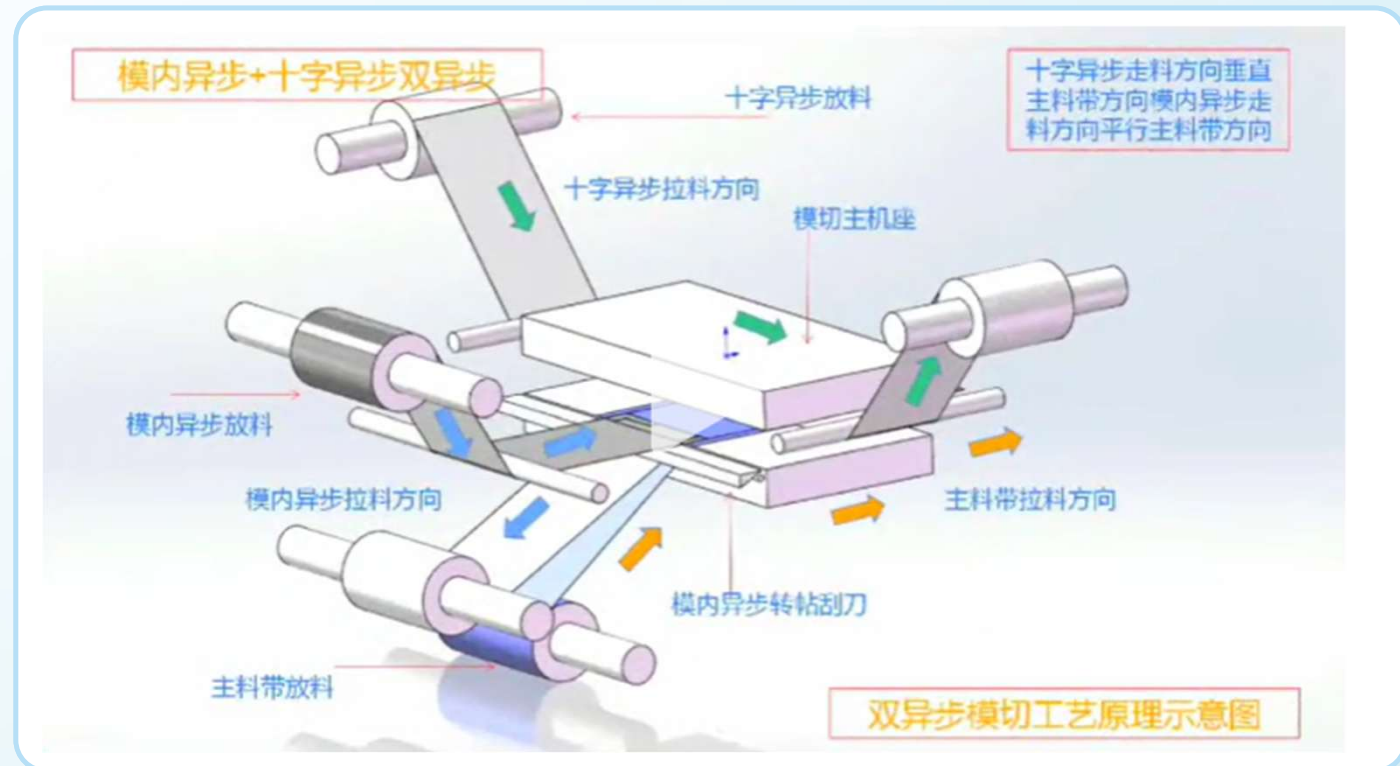

02

PART TWO

异步案例分享

Asynchronous Case Sharing

提供缓冲/密封/防震 解决方案, 提供导热/隔热 解决方案
提供绝缘/防火/安全 解决方案, 提供粘接/密合 解决方案



2. 异步案例分享 (Asynchronous case sharing)

2.1 FPC双面胶Y异步模切工艺

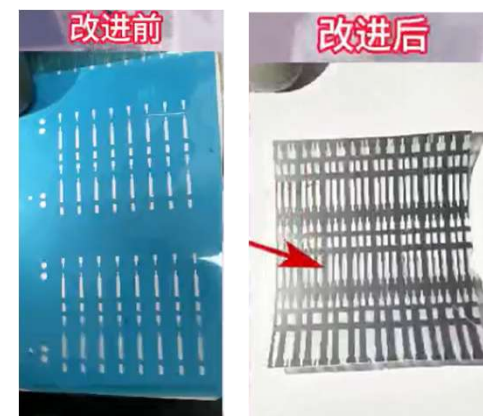

2. 异步案例分享 (Asynchronous case sharing)

2.2 CCD视觉异步对贴模切工艺

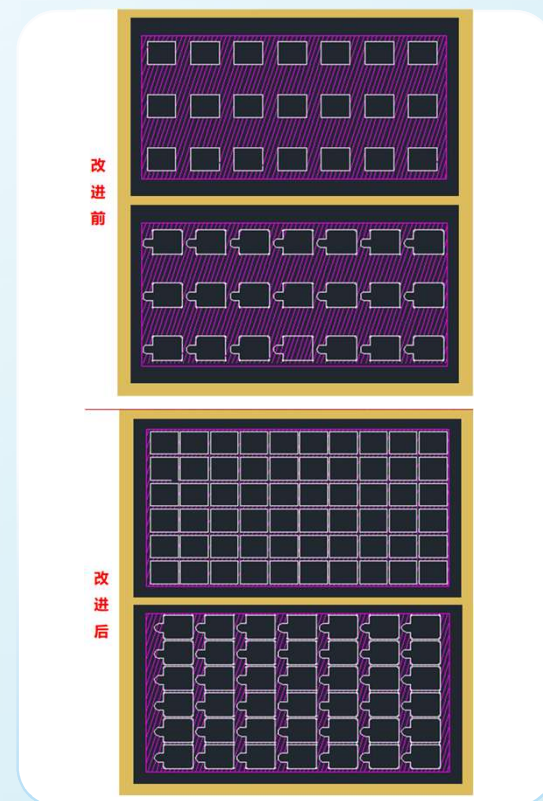

2. 异步案例分享 (Asynchronous case sharing)

2.3 Y异步传统异步组合圆型网布工艺

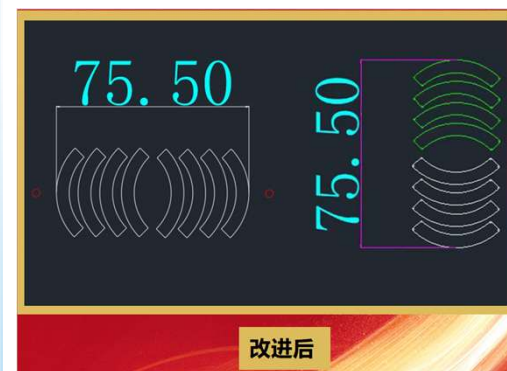
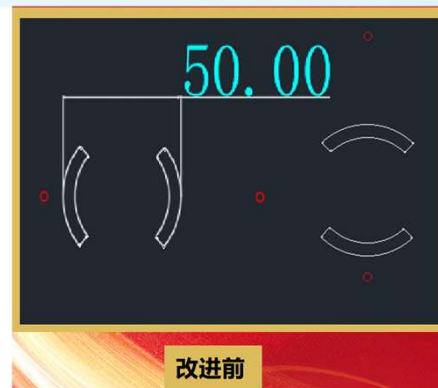

2. 异步案例分享 (Asynchronous case sharing)

2.4 模组大背胶组合线工艺

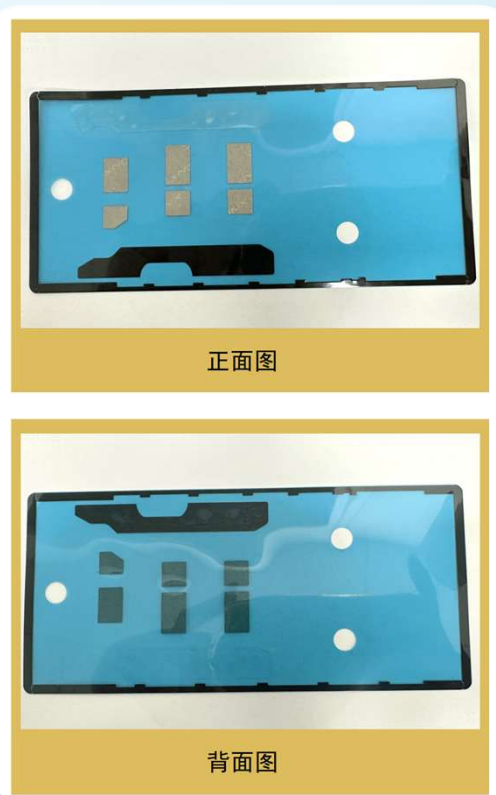
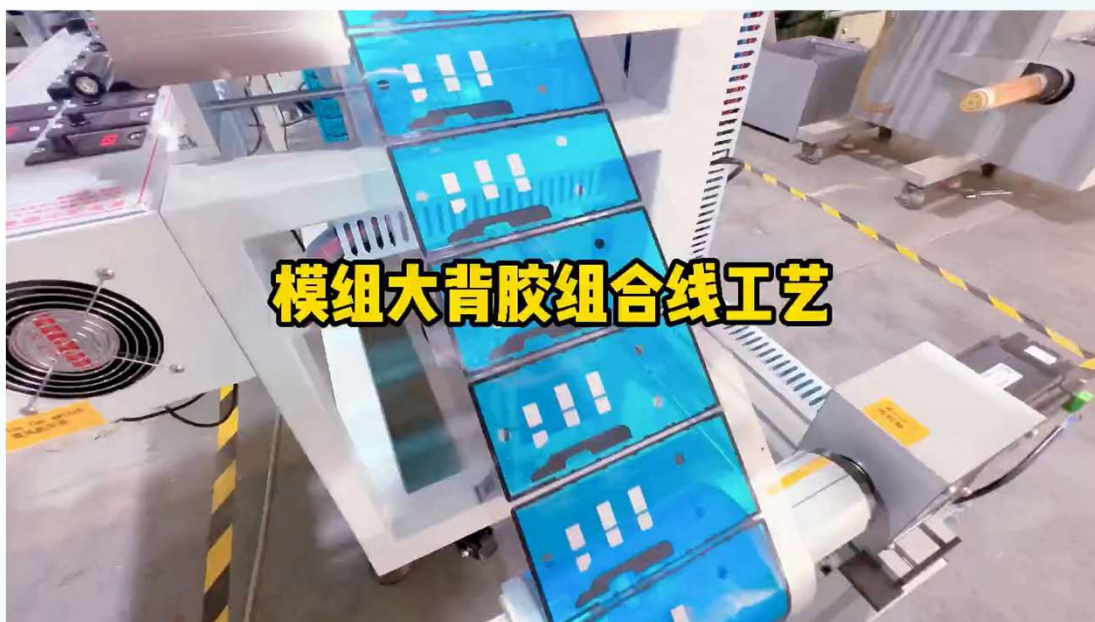

2. 异步案例分享 (Asynchronous case sharing)

2.5 L型CCD对位冲型工艺



改进前

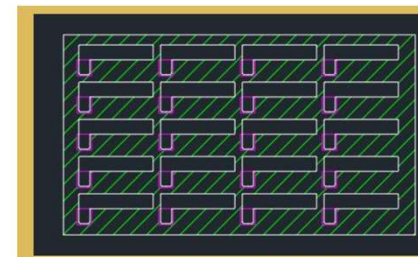

改进后

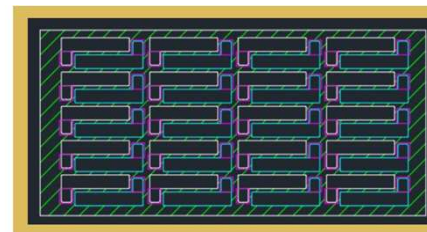

2. 异步案例分享 (Asynchronous case sharing)

2.6 导电布双面胶45度角异步工艺



改进前:

传统异步只能X方向或者Y方向异步, 浪费材料较多, 局限性比较大, 特别针对90度的产品。



改进后:

可以颠覆传统, 45度异步, 产品一出三, 能节省3倍以上材料, 同样成本也降低了300%。

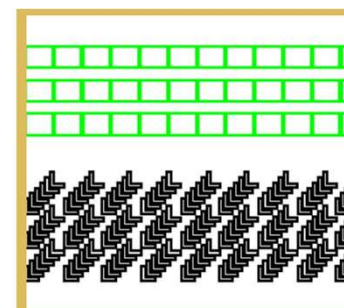

03

PART THREE

其它类型设备

Other Types of Equipment

提供缓冲/密封/防震 解决方案, 提供导热/隔热 解决方案
提供绝缘/防火/安全 解决方案, 提供粘接/密合 解决方案



3. 其它类型设备案例分享 (Case sharing of other types of equipment)

3.1 新能源大面幅油压模切机



3. 其它类型设备案例分享 (Case sharing of other types of equipment)

3.2 硅胶气凝胶塑封

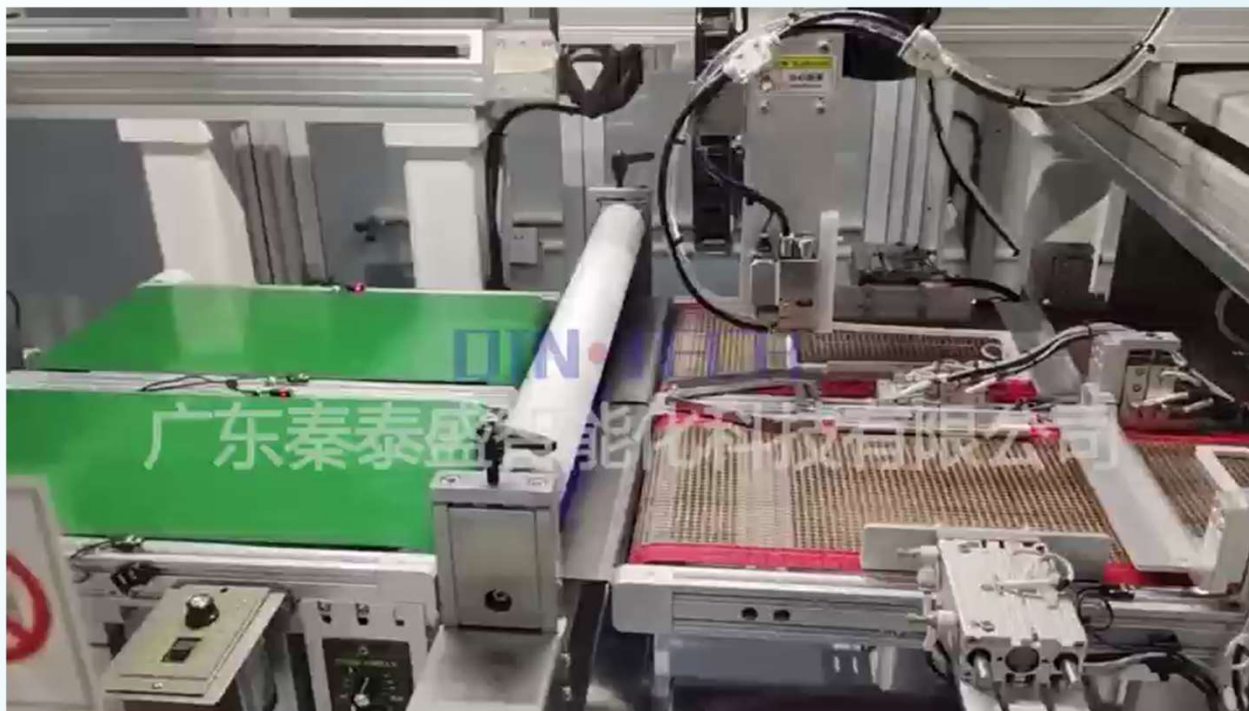

3. 其它类型设备案例分享 (Case sharing of other types of equipment)

3.3 硅胶底涂涂布



3. 其它类型设备案例分享 (Case sharing of other types of equipment)

3.4 高速跳切机



3. 其它类型设备案例分享 (Case sharing of other types of equipment)

3.5 全自动视觉贴合设备

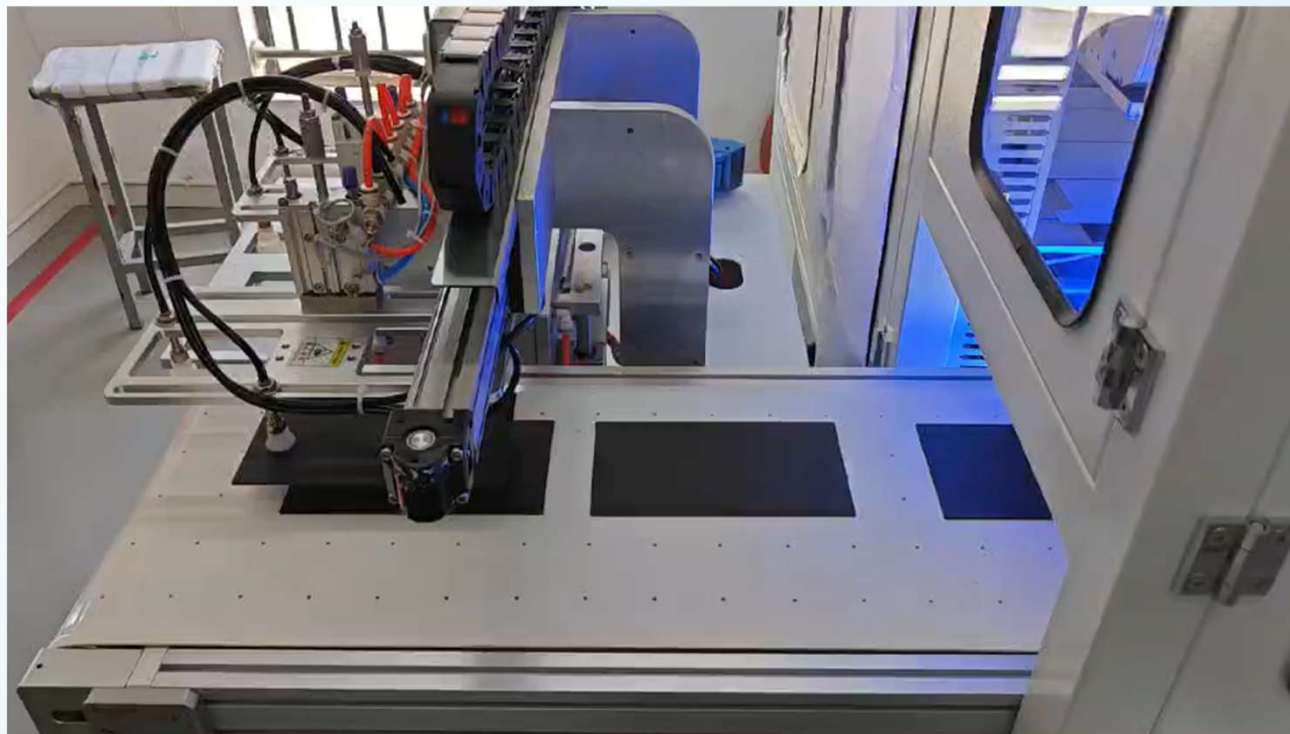



美萨实业

——上海美萨实业有限公司

THANKS!



企业宣传册

李承道 总经理
TonyLi General Manager
☎ 18017127130 ✉ tonyli@shmsa.com

上海美萨实业有限公司
Shanghai MSA Industries Co.,Ltd
地址(Add):上海市金山区金张公路625号2幢
2 Bldg, No.625 Jinzhang Road,
Jinshan District, Shanghai

电话(Tel):+86(21)39901539
传真(Fax):+86(21)39901529
邮编(P.C):201514
网址(Web):http://www.shmsa.com

- 1.提供缓冲/密封/防震 解决方案
- 2.提供导热/隔热 解决方案
- 3.提供绝缘/防火/安全 解决方案
- 4.提供粘接/密合 解决方案

“基于品、始于心”

企业宗旨：立足于产品的品质，用心为客户服务。

提供缓冲/密封/防震 解决方案，提供导热/隔热 解决方案
提供绝缘/防火/安全 解决方案，提供粘接/密合 解决方案

